

GNM 2636 - G 1.4

DC
Geared Motors
with permanent magnet field

Motor series GNM 2636
with + without parking brake
Worm gear series G 1.4
up to 2 Nm

Designs with brake with 1000mm connection cord

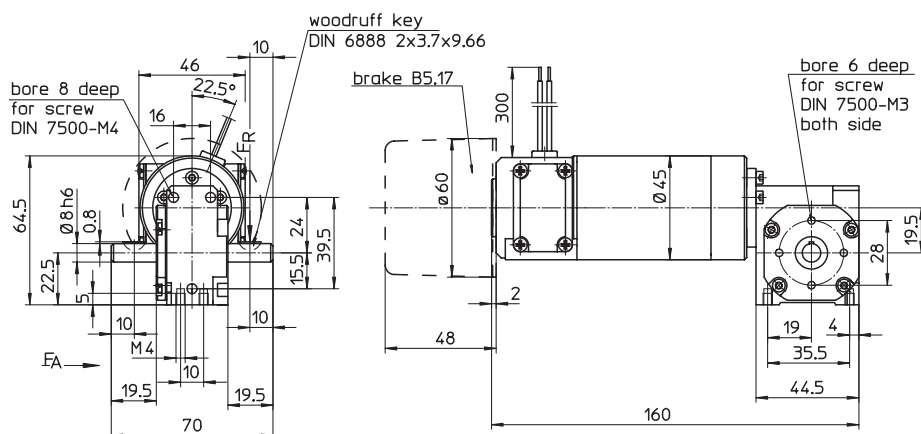

type		GNM 2636 - G 1.4
series		A
operation acc. to standards VDE 0530		S1
isolation acc. to standards VDE 0530		F
protection acc. to standards VDE 0530		IP 41
kind of connection		free leads
rotating direction		reversible
bearing (motor)		ball bearing
bearing (gear box)		ball bearing
gear box		not self-locking, low noise
parking brake B 5.17		
nominal voltage	V	24
nominal current	A	0,3
static brake torque (motor shaft)	Nm	0,5
max. number of operations/h		2000

- Motors also available with DC-tachometer and/ or incremental encoder
- Motors also available in protection IP 54 and/ or with device plug DIN 43650
- Design with brake in protection IP 54 and with cable connection

Motor design:

Worm pinned in the motor shaft. Brush holder opening will be accessible by removing the cover plate. Free leads.

Foot mounting with 4 threads, see drawing.

Rotating direction:

The rotating direction can be changed by inverting the connections.

Order example

Motor - gear box

GNM 2636A - G 1.4

24 V, 3000 rpm - 7,3:1

Special designs on request.

GNM 2636A - G1.4

1 nominal voltage	2 nominal speed	3 nominal torque	4 starting torque	5 nominal torque at undulatory current	6 nominal power	7 nominal current	8 nominal current at undulatory current	9 peak current	10 power gear box input	11 nominal speed gear box input	12 ratio gear box	13 efficiency gear box	load limitations gear box			17 total weight motor + gear box	18 total weight motor + gear box + parking brake	19 F _r (allow. radial shaft load)	20 F _a (allow. axial shaft load) ¹⁾
V	rpm	Nm	Nm	Nm	W	A	A	A	W	rpm	i	%	W	Nm	Nm	kg	kg	N	N
24	411	0,35 ²⁾	1,3 ²⁾	0,25	15	1,4 ²⁾	1,1	6,7	20	3000	7,3 :1	76	15	0,35	2,0	0,8	1,0	110	60
24	261	0,50 ²⁾	2,0 ²⁾	0,38	14	1,4 ²⁾	1,1	6,4 ²⁾	19	3000	11,5 :1	73	14	0,50	2,0	0,8	1,0	110	60
24	200	0,65 ²⁾	2,0 ²⁾	0,47	14	1,4 ²⁾	1,1	5,0 ²⁾	19	3000	15 :1	70	14	0,65	2,0	0,8	1,0	110	60
24	130	1,0 ²⁾	2,0 ²⁾	0,69	14	1,5 ²⁾	1,1	3,4 ²⁾	20	3000	23 :1	67	14	1,0	2,0	0,8	1,0	110	60
24	100	1,1 ²⁾	2,0 ²⁾	0,85	12	1,3 ²⁾	1,1	2,7 ²⁾	18	3000	30 :1	63	12	1,1	2,0	0,8	1,0	110	60
24	79	1,05 ²⁾	1,2 ²⁾	1,0	8,7	1,1 ²⁾	1,1	1,5 ²⁾	14	3000	38 :1	60	8,7	1,05	1,2	0,8	1,0	110	60

Tolerances $\pm 10\%$

Columns 3 and 13

Values are valid at operating temperature after run-in period.

Columns 5 and 8

Current values should not exceeded during operation with undulatory current (single way rectification) with harmonic portion above 5%.

Columns 4 and 9

Figures correspond with the gearbox load limitations. For high gear ratios the allowed currents may be lower than the motors rated current. If so, please the current has to be limited, e.g. through adjusting the servo controller.

Columns 14, 15 and 16

To avoid gear box overload do not exceed the mentioned values. For oscillating operation the mentioned limitations must be multiplied by 0,75.

¹⁾ middle of the shaft-extension

²⁾ motor current must be limited to avoid excess of the mentioned value